

ZAVA

OFFICINE ITALIANE DESIGN

ISTRUZIONI DI MONTAGGIO
ASSEMBLY INSTRUCTION

Rings

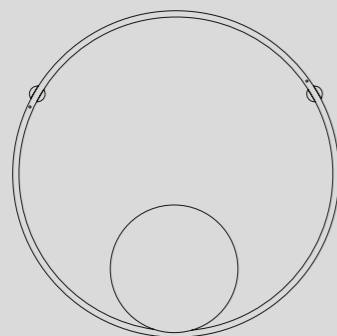

ATTENZIONE

1. Prima di procedere con l'installazione dell'apparecchio e comunque prima di ogni operazione di manutenzione togliere la tensione di rete.
2. Prima di eseguire il cablaggio, innestare il conduttore di terra alla staffa di fissaggio.
3. Se il cavo flessibile esterno di questo apparecchio viene danneggiato, deve essere sostituito esclusivamente dal costruttore, dal suo servizio di assistenza o dal personale qualificato, al fine di evitare pericoli.

WARNING

1. Always unplug the appliance from the power socket before beginning installation or any sort of maintenance work.
2. Before starting the wiring, joint the earth wire to the fixing bracket.
3. If the power lead to the appliance is damaged in any way, it must only be replaced by the manufacturer, an authorised service centre or a qualified electrician to prevent any sort of risk for the user.



La marcatura indica che sono state superate positivamente tutte le prove previste dalle normative per la sicurezza elettrica richieste dalla Comunità Europea. Normative EN 60598-1 corrispondenti alle norme italiane per la sicurezza elettrica CEI 34-21.
This mark guarantees that the product has passed all the test established for electrical safety standards by the European Community. EN 60598-1 corresponding to Italian standards for electrical safety CEI 34-21.



Apparecchio di classe I (la sicurezza viene garantita con la messa a terra).
Equipment Class I (safety is ensured by connecting the fitting to the ground)



Simbolo che identifica la classificazione secondo il grado di protezione contro la penetrazione di polvere, di corpi solidi e di umidità.
Index protection. A symbol that identifies the protection index against dust, solid particles or damp entering the fixture.



Questo prodotto deve essere smaltito in modo differenziato dai rifiuti urbani. Non trattare il prodotto come rifiuto ordinario.
This product should be disposed separately from normal urban rubbish. It may not be treated as household waste.



Dimensioni / Dimensions:

- Ø30 x p. 4 cm, box Ø11 x sp.4 cm.
- Ø40 x p. 4 cm, box Ø11 x sp.4 cm.
- Ø50 x p. 4 cm, box Ø13 x sp.4 cm.
- Ø80 x p. 4 cm, box Ø13 x sp.4 cm.
- Ø115 x p. 4 cm, box Ø18,5 x sp.4 cm.
- Ø135 x p. 4 cm, box Ø18,5 x sp.4 cm.
- Ø145 x p. 4 cm, box Ø20,5 x sp.4 cm.
- Ø150 x p. 4 cm, box Ø20,5 x sp.4 cm.
- Ø190 x p. 4 cm, box Ø20,5 x sp.4 cm.

Sorgente luminosa / Light source:

- Ø30cm LED 10,5W 24Vcc 4000K/3000K/2700K 935Lm/828Lm/735Lm Energy Class A
- Ø40cm LED 14W 24Vcc 4000K/3000K/2700K 1243Lm/1105Lm/980Lm Energy Class A
- Ø50cm LED 17W 24Vcc 4000K/3000K/2700K 1555Lm/1381Lm/1190Lm Energy Class A
- Ø80cm LED 28W 24Vcc 4000K/3000K/2700K 2486Lm/2210Lm/1960Lm Energy Class A
- Ø115cm LED 40W 24Vcc 4000K/3000K/2700K 3575Lm/3177Lm/2800Lm Energy Class A
- Ø135cm LED 47W 24Vcc 4000K/3000K/2700K 4196Lm/3730Lm/3290Lm Energy Class A
- Ø145cm LED 50W 24Vcc 4000K/3000K/2700K 4507Lm/4006Lm/3500Lm Energy Class A
- Ø150cm LED 51W 24Vcc 4000K/3000K/2700K 4662Lm/4144Lm/3570Lm Energy Class A
- Ø190cm LED 65W 24Vcc 4000K/3000K/2700K 5788Lm/5280Lm/4550Lm Energy Class A

CUSTOMER SERVICE

Zava S.r.l.
Via Padova 48 - 31041 Cornuda (TV) Italy
T.+39.0423.639907 F.+39.0423.821639

1

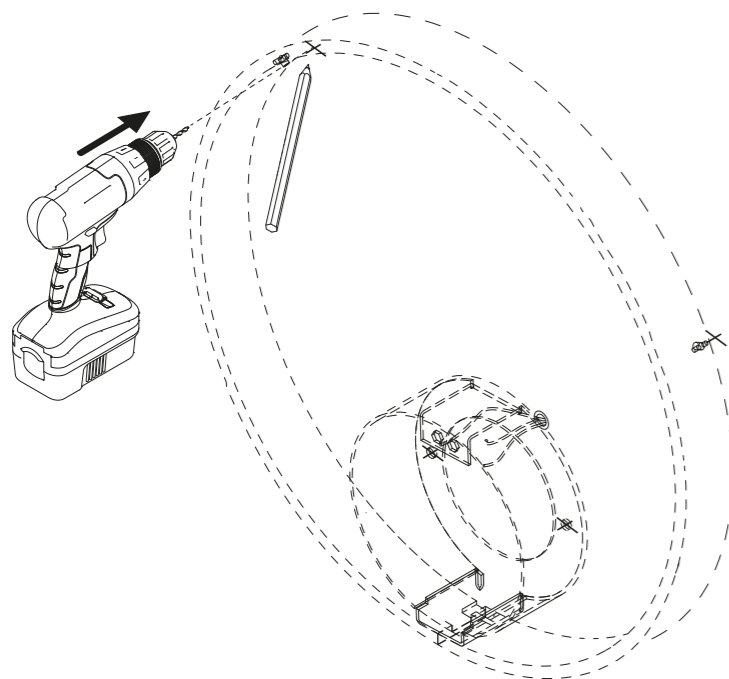

2

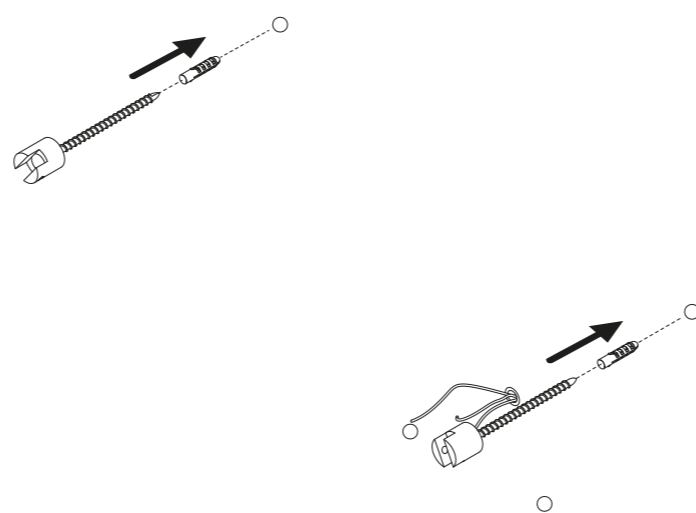

3

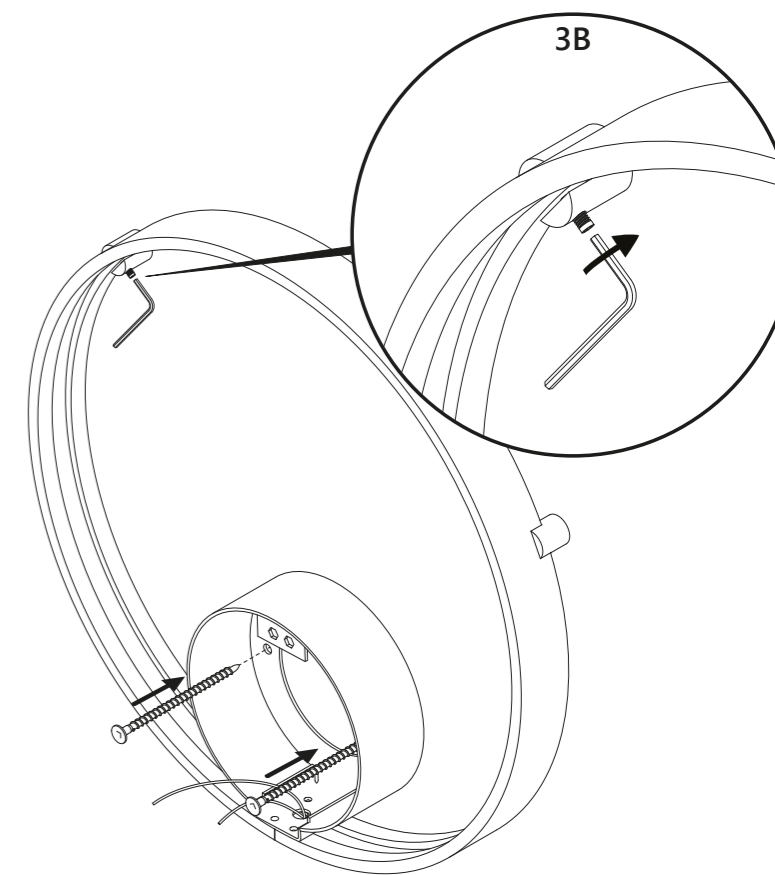

4

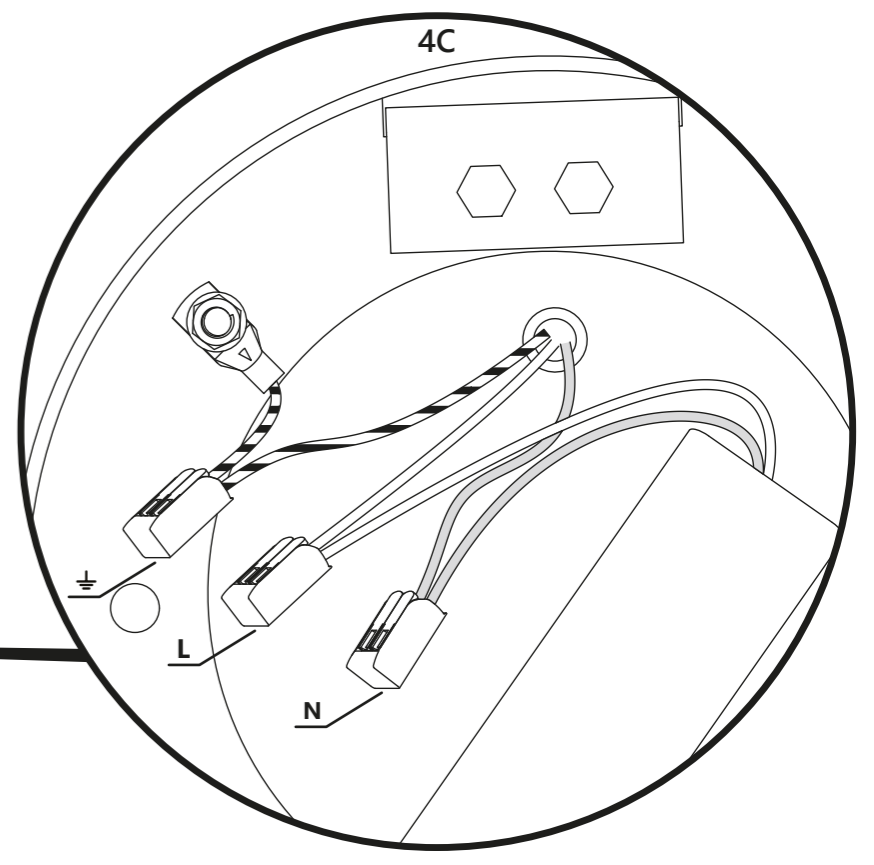
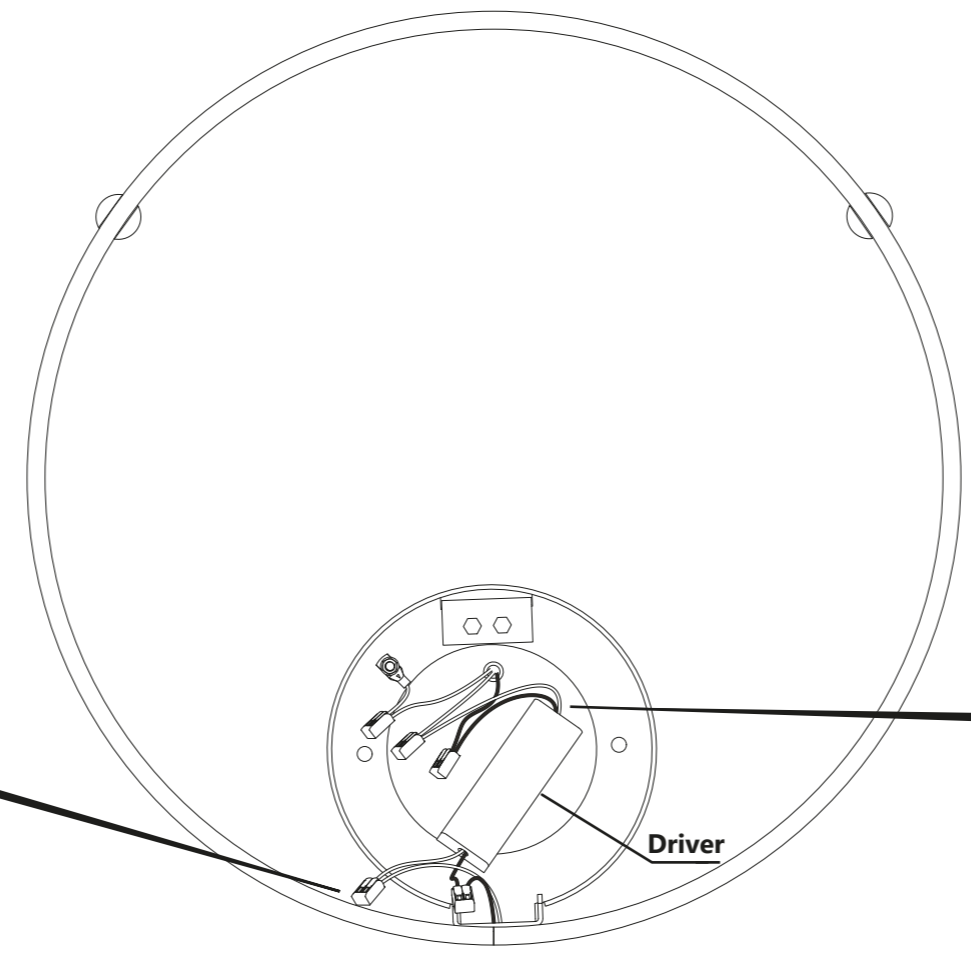
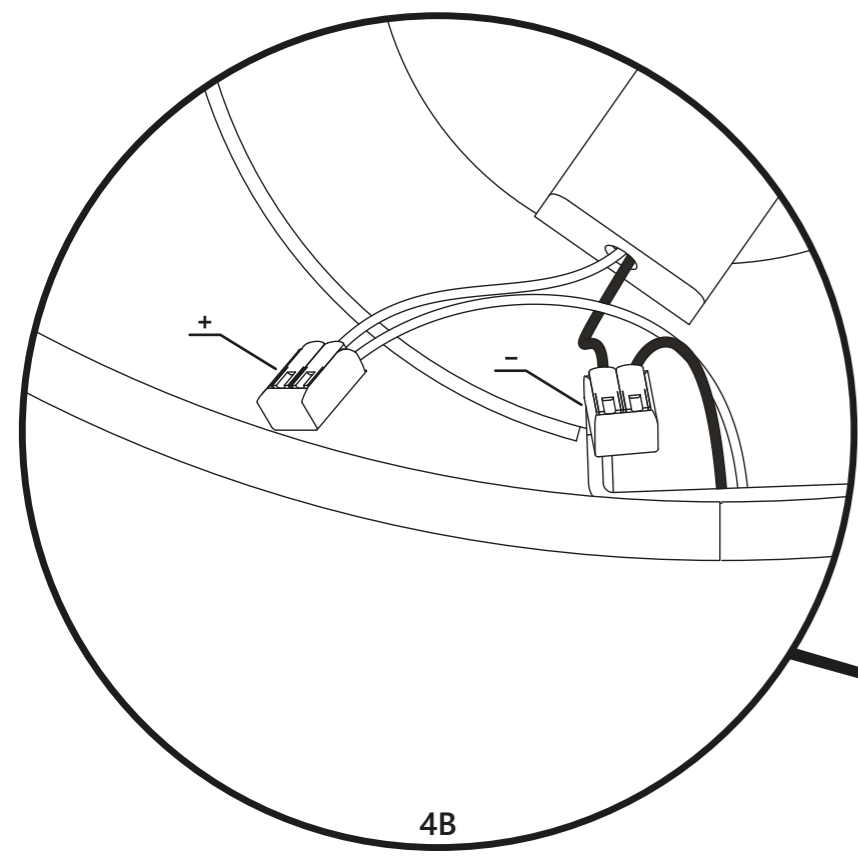

5

